

REVISION HISTORY				
ZONE	REV	DESCRIPTION	DATE	APPROVED
All	1	Released	3/14/2011	RLC

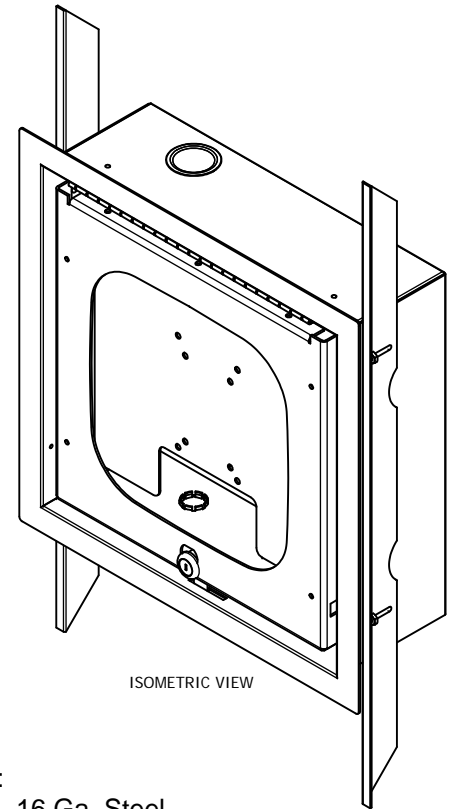
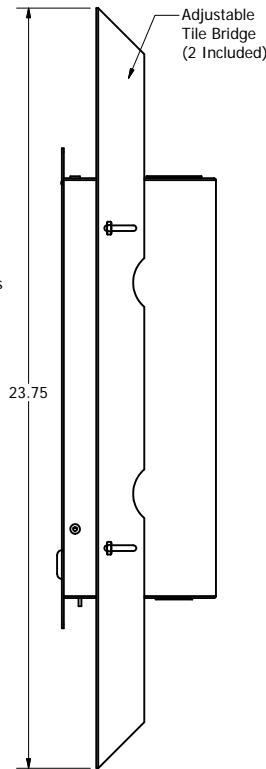
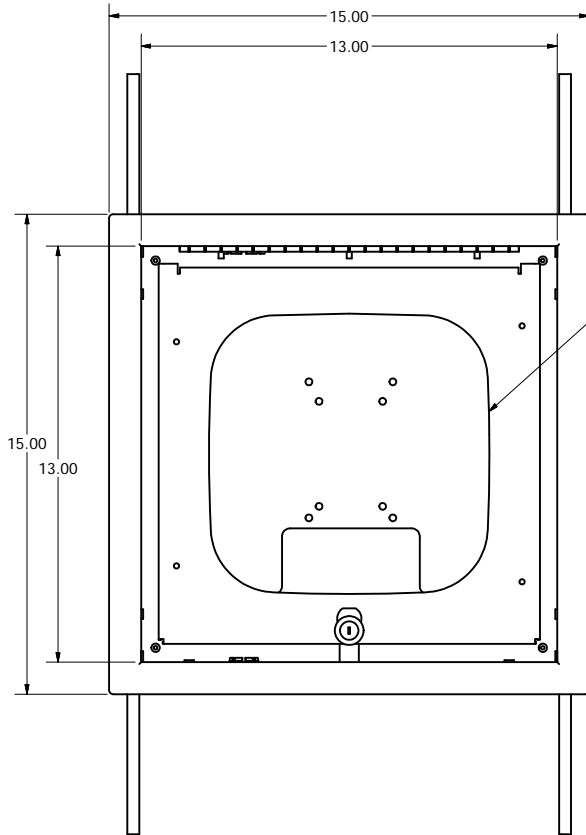
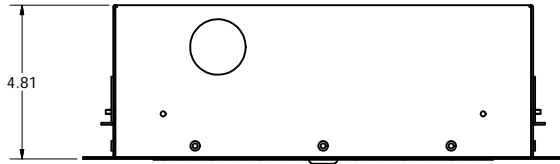

ISOMETRIC VIEW

NOTE:

- Material:**
Back Box - 16 Ga. Steel
Door - 14 Ga. Steel
Tile Bridge - 16 Ga. Aluminum
- Finish:** White Powder Coat
- Weight:** 11 lbs.
- Complies with NEC300-22 and 300-23 for plenum installations
- To be installed in accordance with NEC 300.11(A), and other applicable code sections, whereby a separate support wire is to be installed in addition to the ceiling grid support wire. The independent support wire must be secured at both ends

DRAWN	RLC	3/14/2011	Oberon, Inc. - 1315 S. Allen St. - State College, PA 16801	
CHECKED	RLC	3/14/2011	TITLE	
QA			Model WC-AP3500-X	
MFG	RLC	3/14/2011	SIZE	DWG NO
APPROVED	RLC	3/14/2011	C	WC-AP3500-X
TOLERANCE:	.0 = +/- .030		SCALE	REV
	.00 = +/- .015			1
	.000 = +/- .005			
			SHEET 1 OF 1	